

UNIVERSAL TYPE DIGITAL PANEL METER

A7000

SERIES



ASAHI KEIKI CO., LTD.

9 0000 0000 A7000 0000

www.asahi-keiki.co.jp

Input Specifications

■ DC voltage,current

• A7X11-X

Range	Measurement Range	Display	Input Protection	Accuracy (23°C ± 5°C, 35 ~ 85% RH)
11	±99.99 mV	offset ±9999 full scale ±9999	±50 V	±(0.03% of rdg + 1digit)
12	±999.9 mV		±50 V	
13	±9.999 V		±250 V	
14	±99.99 V		±250 V	
15	±700 V		±700 V	

Conversion rate: 1000times/sec

• A7X12-X

Range	Measurement Range	Display	Input Protection	Accuracy (23°C ± 5°C, 35 ~ 85% RH)
21	±99.99 uA	offset ±9999 full scale ±9999	±10 mA	±(0.1% of rdg + 2 digit)
22	±999.9 uA		±50 mA	
23	±9.999 mA		±50 mA	
24	±99.99 mA		±700 mA	

Conversion rate: 1000times/sec

• A7X13-X

Range	Measurement Range	Display	Input Protection	Accuracy (23°C ± 5°C, 35 ~ 85% RH)
25	±999.9 mA	offset ± 9999	±3 A	±(0.1% of rdg + 2 digit)
26	±2.000 A	full scale ±9999		

Conversion rate: 1000times/sec

■ AC voltage, current (TRUE-RMS)

• A7X14-X

Range	Measurement Range	Display	Input Protection	Accuracy (23°C ± 5°C, 35 ~ 85% RH)
11	99.99 mV	offset ±9999 full scale ±9999	50 V	±(0.2% of rdg + 20 digit)
12	999.9 mV		50 V	
13	9.999 V		250 V	
14	99.99 V		250 V	
15	700.0 V		700 V	

Minimum display 50 digits
Frequency range: 40Hz to 1kHz
Response time: Approx 1 sec(10% to 90%)
Conversion rate: 1000times/sec

• A7X15-X

Range	Measurement Range	Display	Input Protection	Accuracy (23°C ± 5°C, 35 ~ 85% RH)
21	99.99 uA	offset ±9999 full scale ±9999	10 mA	±(0.5% of rdg + 20 digit)
22	999.9 uA		10 mA	
23	9.999 mA		50 mA	
24	99.99 mA		500 mA	

Minimum display 50 digits
Frequency range: 40Hz to 1kHz
Response time: Approx 1 sec(10% to 90%)
Conversion rate: 1000times/sec

• A7X16-X

Range	Measurement Range	Display	Input Protection	Accuracy (23°C ± 5°C, 35 ~ 85% RH)
25	999.9 mA	offset ±9999	3 A	±(0.7% of rdg + 20 digit)
26	5 A	full scale ±9999	8 A	

Minimum display 50 digits
Frequency range: 40Hz to 1kHz
Response time: Approx 1 sec(10% to 90%)
Conversion rate: 1000times/sec

■ Resistance

• A7X17-X

Range	Measurement Range	Display	Current	Accuracy (23°C ± 5°C, 35 ~ 85% RH)
11	99.99 Ω	offset ±9999 full scale ±9999	5 mA	±(0.1% of rdg + 4digit)
12	999.9 Ω		0.5 mA	
13	9.999 KΩ		50 uA	
14	99.99 kΩ		5 uA	

Conversion rate: 100times/sec
Measurement method: Two or Four wire (internal socket changable)

■ Thermocouple • RTD

• A7X18-X

Range	Sensor type	Measurement Range	Maximum Resolution	Accuracy (23°C ± 5°C, 35 ~ 85% RH)
KA	K	-50.0 to 199.9°C	0.1°C	±(0.5% of FS)
KB	K	-50 to 1200°C	1°C	±(0.2% of FS)
J	J	-50 to 1000°C	1°C	±(0.2% of FS)
T	T	-50 to 400°C	1°C	±(0.6% of FS)
S	S	0 to 1700°C	1°C	±(0.4% of FS)
R	R	-10 to 1700°C	1°C	±(0.4% of FS)
B	B	100 to 1800°C	1°C	±(0.4% of FS)
PA	PT100 Ω	-100.0 to 199.9°C	0.1°C	±(0.15% of FS)
PB	PT100 Ω	-100 to 600°C	1°C	±(0.3% of FS)

available Fahrenheit display
Cold junction compensator accuracy : ±2°C (10 to 40°C)
Sensor lead resistance : less than 50 Ω
Linearizing method : Digital linearizing
Burn out alarm : - - - -
Conversion time : 2.5times/sec

■ Frequency

• A7X19-X

Range	Measurement Range	Accuracy (23°C ±5, 35 ~ 85% RH)
11	0.1 to 999.9 Hz	±(0.2% of FS)
12	1 to 9.999 kHz	
13	10 to 99.99 kHz	

Input type	Input voltage level	Input Protection
Open collector	L: less than 1.5 V (5V, pullup)	30 V
Logic	L: less than 1 V, HI: 2.5 to 15 V	15 V
Magnet	0.3 to 30 V P-P	30 V
Voltage	30 V rms to 500 V rms	500 V

Prescale : 0.01 ~ 10.00
 PPR : 1~100
 Power supply for sensor : 12 VDC ±10%

■ Strain gauge

• A7X1A-X

sensor	Zero adjustment range	Span adjustment range	Measurement range	Accuracy
5 V	-1 to + 1 mV/V	1 to 3mV/V	-4 ~ + 4 mV/V	±(0.1% of FS) + 2 digit
10 V				

Sesnor : 350 Ω
 Power supply for sensor : 5 V ± 5% (less than 15 mA)
 10 V ± 5% (less than 30 mA)
 Conversion speed : 1000/sec

■ Process

• A7X1B-X

sensor	Measurement Range	Display	Accuracy
1 V	1 to 5 V	offset: ±9999 full scale 0 to ±9999	±(0.03% of rdg + 2digit) ±(0.1% of rdg + 3digit)
2 V	±5 V		
2 A	4 to 20 mA		
3 A	±20 mA		

Conversion rate : 1000times/sec
 Excitation power supply : 12 VDC ±5%
 24 VDC ±5% 25 mA

Output Specification

• HH, HI & LO, LLsetpoints output

Comparative condition:

Indication > High High setpoint	HH
High High setpoint ≧ Indication > High setpoint	HI
High setpoint ≧ Indication ≧ Lo setpoint	GO
Low setpoint > Indication ≧ Low Low setpoint	LO
Low Low setpoint > Indication	LL

Setting range : -9999 to 9999
 Hysteresis : 1 to 999 digit for each setpoints
 Relay contact capacity : AC125 V 0.3 A resistive load
 DC30 V 1 A resistive load
 Photocoupler capacity : DC30 V 50 mA

• BCD output

Type of output : Open collector or TTL
 Logic : Changeable
 Output rate : DC30 V 10 mA (open collector)
 Funout 2 (TTL)

• Analog output (PWM)

output	Load resistance	Accuracy	Ripple
0 to 1 V	more than 10 kΩ	±(0.5% of F.S)	±50 mV p-p
0 to 10 V			
1 to 5 V			
4 to 20 mA	less than 550 Ω		±25 mV p-p

Output method : PWM method
 Scaling : Digital scaling
 Resolution : 13 bit
 Reponse time : approx 0.5 sec

• RS232C (Conforming to EIA RS-232C)

Communication method : Full duplex
 Transmission speed : 4800/9600/19200/38400 bps
 Start bit : 1 bit
 Data length : 7 bit/8 bit
 Parity : Even parity/ odd parity
 Stop bit : 1 bit/2 bit
 Character code : ASCII code
 Transmission control process : Ignord process

• RS-485 (conforming to EIA RS-485)

Communication method : Full duplex
 Transmission speed : 4800/9600/19200/38400 bps
 Start bit : 1 bit
 Data length : 7 bit/ 8 bit
 Parity : Even parity/ odd marity
 Error detection : BCC
 Stop bit : 1 bit/2 bit
 Character code : ASCII code
 Transmission control process : Ignord process
 Signal name : +non reversal output
 -reversal output
 Maximum no of meter connected : 31
 Line length : up to 500m in total

Common Specification

Maximum display	: 9999	
Overrange indication	: When input exceed the maximum display display OVER or -OVER	
Zero display	: Leading zero suppression	
Decimal point	: Settable to any digit position	
Operating temp	: 0 to 50°C (35 to 85% RH)	
Storage temp.	: -10 to 70°C less than 60%RH	
Power supply	: 100 to 240VAC ± 10%	
	12 to 48VDC	
Power consumption	: 8VA (At AC) 7W(At DC)	
Dimensions	: 72mm (W) × 36mm (H) × 118mm (D)	
Weight:approx	: 160g	
Dielectric strength (AC)	: Power supply/input terminal/output terminal	AC1500 V/min
	(DC) : Power supply/input terminal/output terminal	DC500 V/min
	: Input terminal/output terminal	DC500V/min
Insulation resistance	: DC500V more than 100MΩ at the above terminals	

Dimensions

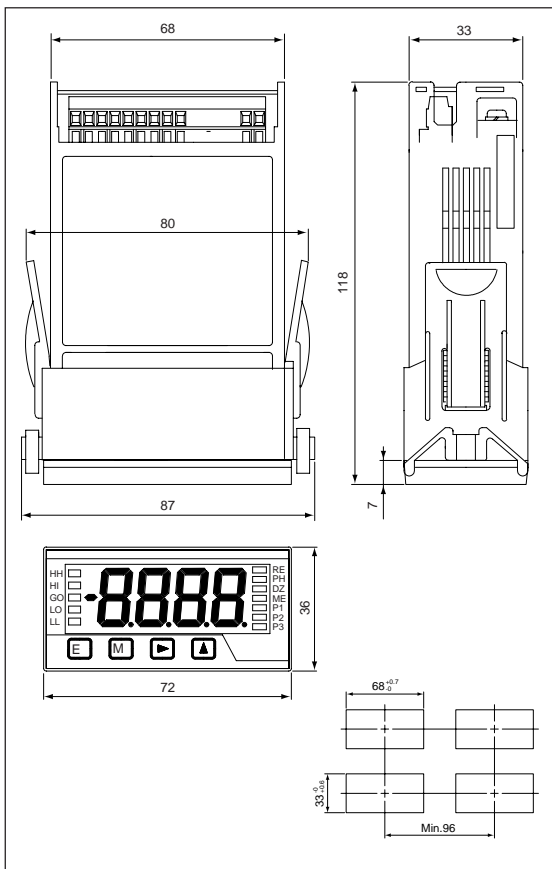

Ordering Code

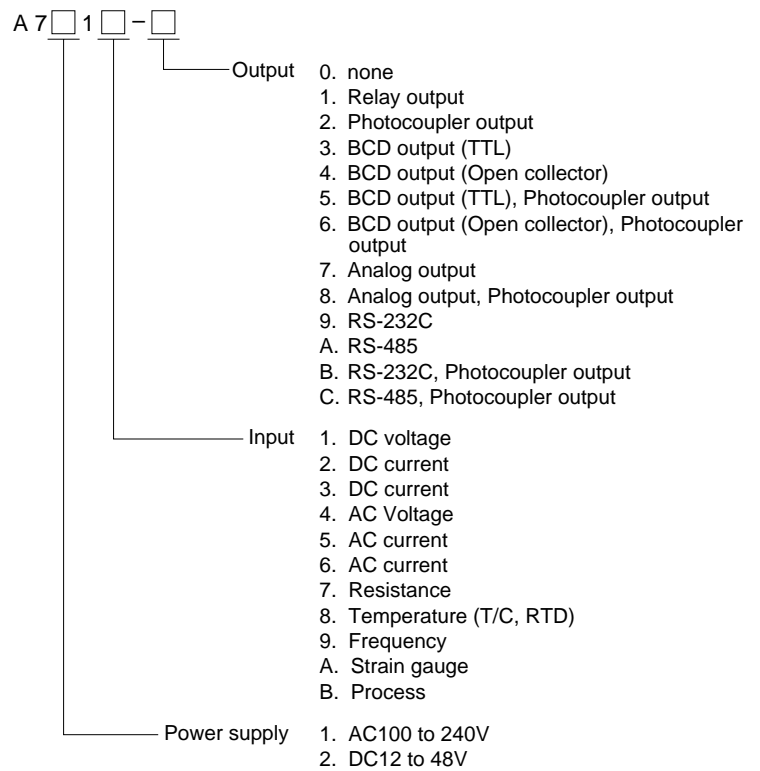

We reserve the right to change specifications without notice.



ASAHI KEIKI CO., LTD.

33-6, YAGUCHI 2-CHOME, OHTA-KU,
 TOKYO 146-8505, JAPAN
 FAX : (03)3757-2989
 PHONE: (03)3579-3893
[http:// www.asahikeiki.co.jp](http://www.asahikeiki.co.jp)
 E-mail: dpm-overseas@asahikeiki.co.jp